

August 9, 2024

ADDENDUM NO.01 to the plans and specifications for the Macomb County Clemens Center, County Clerk Storage Renovations, Mt. Clemens, MI, Architect's Project No. 231987, dated July 25, 2024.

The above plans and specifications are modified, supplemented or augmented as follows, and this ADDENDUM NO. 01, is hereby made a part of the contract documents.

Drawings G0.0, A1.1, A1.2, Sign In Sheet from Pre-Bid Meeting (8/1/24) and Architectural Specifications 09650, 09970, 12364 and RFI Question Sheet (answers are contained in Addendum) are being issued with this Addendum.

ARCHITECTURAL SPECIFICATION ITEMS:

- ITEM NO. AS1:** See attached 09650 (re-issued)
1. 2.02 Accessories, A. Resilient Base, Item 1 letter e. Remove letter e.
- ITEM NO. AS2:** See attached 09650 (re-issued)
1. 2.02 Accessories, B. Resilient Molding/Reducer/Floor Finishing Accessories, Clarified transition pieces. Item 1 letter a.
Carpet to LVT: CTA-XX-D
Painted or sealed concrete to LVT: EG-XX-J.
- ITEM NO. AS3:** See attached 09970 (re-issued)
1. Revised Section 09970 – High Performance Coating Systems, Part 2 Products, 2.4 Painted Exposed Interior Structural Steel to 2.4A Painted Exposed Interior Structural Steel.
- ITEM NO. AS4:** See attached 09650 (re-issued)
1. Revised Section 09970 – High Performance Coating Systems, Part 2 Products, added 2.4B Coating Systems for Concrete Floors (Decorative Chip.)
- ITEM NO. AS6:** See attached 12364 (issued)
1. Added Section 12364 – Quartz Surfaces

ARCHITECTURAL DRAWING ITEMS:

- ITEM NO. A1:** See attached G0.0 (re-issued)
1. Revised drawing index.
- ITEM NO. A2:** See attached A1.1 (re-issued)
1. Revised door schedule door A104 to (2)3'-0"X7'-0" HM doors.

- ITEM NO. A3:** See attached A1.1 (re-issued)
1. Added door frame type 2.
- ITEM NO. A4:** See attached A1.1 (re-issued)
1. Revised room finish note number 2 to abuse resistant gypsum board.
- ITEM NO. A5:** See attached A1.1 (re-issued)
1. Clarified flooring notes on new work floor plan 2.
- ITEM NO. A6:** See attached A1.1 (re-issued)
1. Deleted room name location A105 Alcove. Included with corridor A102. Assume room finishes shall match corridor A102 in room finish schedule. Assume multiple paint colors will be used.
- ITEM NO. A7:** See attached A1.1 (re-issued)
1. Clarified using abuse resistant gypsum board in lieu of hi-abuse gypsum board.
- ITEM NO. A8:** See attached A1.1 (re-issued)
1. Added dimensions for supported slab at new door opening.
- ITEM NO. A9:** See attached A1.1 (re-issued)
1. Added locations and notes showing existing fiber optic locations.
- ITEM NO. A10:** See attached A1.1 (re-issued)
1. Added location, dimension and notes showing existing iron elbow and piping.
- ITEM NO. A11:** See attached A1.1 (re-issued)
1. Added finish note for old alcove A105 now corridor A102.
- ITEM NO. A12:** See attached A1.2 (re-issued)
1. Revised detail notes on detail 7.
- ITEM NO. A13:** See attached A1.2 (re-issued)
1. Revised room tag name on enlarged plan number 7 to New Clerk Storage – A105.

END OF ADDENDUM NO. 01

Cc: Mary Schultz, Macomb County
Benjamin Treppa, Macomb County
Anthony Torelli, Macomb County
Ron Syme, Wakely Associates

MACOMB COUNTY
 CLEMENS CENTER
 COUNTY CLERK STORAGE RENOVATIONS
 WAKELY PROJECT #231987

PRE-BID MEETING
 SIGN-IN SHEET
 August 1, 2024
 10:00 a.m.

NAME	FIRM	PHONE NO.	FAX NO.	EMAIL
SEAN GECROT	BCS STAN	313-264-8845		estimating@buesfrank.com
Brian Wickowski	Advantage Business Systems Professional Help Density Security	989-992-0636 248		brian@organize3d.com
Char Chamberlain	Shelving + Rack Systems	360-0948		chamberlain@srsein.com
Dart Spencer	Casper Corp	248-388-4065		dartspencer@casperc.com
Larry Pagosto	Hutchinson Welds	586-786-0060		hutchinsonwelds.com@gmail.com
Diane / Matt Spink	Spartan Construction Group	(734) 331-5061		matt@spartan-construction.com
Kristina Kile	Decima US	2366593711		kristina.kile@decima.com
Clint Miller	Miller-Boldt	586-997-3300		clint@mlr-boldt.com
Wade Collins	Welder-Beck	586-6343705		wade@wbeck.com
Mica Bressak	Bresnak Erection	(5) 201-4415		mb@bayate.com
Boe Watts	Conventional Carpet	(48) 760-8047		Dwatts@conventionalcarpet.com
VINAY SHENOY	WINSTAR CONTRACTING, LLC	313-247-4319		vinay@winstarcontracting.com
Brian Bonmariti	Custom Woodworks	586-350-2580		customwoodworksllc@yahoo.com

Regis S. Lester	Borwick Inc	313 4078774	DLester@BorwickInc.com
Hannah Lester	Pivotal	248-781-5803	hlongster@pivotal.com
Jessica Stighner	US2Team LLC	248-396-8986	JESSICA@US2TEAM.COM
Doug Fraley II	STW Drywall Inc.	210-533-4180	smdrywall@comcast.net
Matt Ross	D&S Contractors Inc	248-584-4848	mross@dsccontractors.com
David Alexander	Quadrata Cor	588-9044712	David@quadrata.com
Kaitlin Norush	Summit Co.	734-9047191	knorush@summitcompany.com
Jeff Gerasians	Elite Metal (FP)	248-256-9524	jeffg@elitefire.com



Macomb County Finance Department

Purchasing Division

August 9, 2024

TO: ALL BIDDERS

FROM: MARY SCHULTZ, SENIOR BUYER
PURCHASING DIVISION

SUBJECT: RFB 20-24
QUESTIONS AND ANSWERS
Macomb County Clemens Center- County Clerk Storage Renovation

1. Is this a GC bid, it is unclear whether the shelving will be purchased through the GC. Although it may be easier for you to do this, it's not in the best interest of the county to do this as the GC will mark it up and the shelving supplier must charge tax. It specifies spacesaver shelving. I would like to add "or approved alternate". Only one company in this area can sell spacesaver making it not a competitive situation. They can charge whatever they want to the county as they are the only supplier. I have many systems that would fit the bill here and do an excellent job.
2. When is the expected start date of this project?
3. Regarding the High-Density Storage room A104, how much LVT will be getting installed in that room? It says that both LVT and EP are getting installed but I'm having trouble figuring out which material goes where, specifically in that storage room.
4. Sht. Plan A1.1 Room Finish Schedule shows Room A105 Clerks Storage. On plans it refers to A-105 Alcove.
5. Sht. Plan A1.1 Room Finish Schedule shows Room A104 High-Density Storage but no floor to deck elevations.

6. Sht. Plan M1.00 Mechanical New Work Lower-Level Floor Plan calls out 28" round duct to be above new light fixtures. Sheet Plan EL1.00 Lighting New Work Lower-Level Floor Plan and Sheet Plan A1.2 Reflected Ceiling Plan Room 104 High Density Storage does not show what height from floor to bottom of light fixtures. This is also needed for the Mechanical Contractors for installation of the new ductwork above new light fixtures in this area.
7. We did not see the fiber optic or the elbow on the drawings. The fiber optic will be an issue since it will interfere with the new sidewalk placement. The elbow will possibly interfere with the new double doors at the new entrance.
8. There is an existing Fiber Optic (Yellow) 3' marker pole at the corner where the new sidewalk will be placed close to the street curb. The fiber optic appears to run under the existing sidewalk to a connection on the West Elevation of the building.
9. Room Finish Schedule shows Room A105 Clerks Storage. On plans it refers to A105 Alcove.
10. Reflected Ceiling Plan Room 104 High Density Storage does not show floor to deck height.
11. Mechanical New Work Lower-Level Plan calls out 28" round duct to be above new light fixtures. Will need light fixture elevation in reflected ceiling plan.
12. Room 104 High Density Storage does not show height from floor to bottom of light fixtures.
13. Power New Work Lower-Level Plan calls out (12) wall communications Devices and (2) at 6" above counter tops. Who is supplying cabling, installations, connections, covers and labeling? I am assuming we are providing boxes and conduit. Are we running conduit just above ceiling grid and stopping there?
14. Power New Work Lower-Level Floor Plan calls out (4) cameras. New Work Keyed Notes #7 calls out new junction boxes for future cameras. Are we providing power, what voltage, conduit runs, and if so, which circuit on Panel RP-S?
15. New Work Floor Plan shows (2) locations for Humidifiers. Keyed Note 1 calls out CW lines and connection to Humidifiers. Who is supplying Humidifiers and connections to them?
16. New Work Floor Plan does not show the existing door off the corridor into A105. During the bid walk through we were certain there was a door there. Nothing shown on the demo plan or door schedule.

17. There is also an existing either galvanized or iron elbow through the wall from the high-density storage area to the outside elevation where the new double doors are going to be.
18. Is there somebody's proprietary BAS in the building who needs to be involved in this project?
19. Is there any Temperature Control work required for the two new Liebert AC units being installed?
20. The specifications for the quartz are not listed. Do you have a manufacturer/color we should use? With the various cost levels, we would like to make sure we are on the same page.
21. Drawing A1.1 High Density Shelving Elevation Legend shows drawers in U12 and U13 without heights listed. Could the interior drawer height required (item height inside of drawers) be provided to ensure the correct drawer height is utilized?
22. Drawing A1.1 New Work Floor Plan Keynotes 13 for 7/A1.2 states "New Open Shelving Units. Refer to legend". High-Density Shelving Legend provided does not show U3 and U4 static shelving elevation, should they match another elevation, or do they have a different number of shelf openings?
23. Drawing A1.1/ 7 Section Detail- Recessed Rail System. Should the drawing be revised? Drawing states, "First Pour of Conc." and "Second Pour", which is generally utilized for new construction. As this project includes "Sawcut Trench in Existing Concrete Slab", there is only one concrete pour to fill the trench after the rail (including anchors/hydraulic grout) installation.

SECTION 09650 - RESILIENT FLOORING

PART 1 - GENERAL

1.01 RELATED DOCUMENTS:

- A. Attention is directed to Division 0, Bidding and Contract Requirements, and to Division 1, General Requirements, which are hereby made a part of this Section.

1.02 DESCRIPTION OF WORK:

- A. The extent of resilient flooring and accessories is shown on the drawings and in schedule indicated as "LVT" for "Luxury Vinyl Tile Floor".

1.03 QUALITY ASSURANCE:

- A. Wherever possible, provide resilient flooring and accessories produced by a single manufacturer.
- B. Fire Test Performance: Provide resilient flooring which complies with the following fire test performance criteria as determined by an independent testing laboratory acceptable to authorities having jurisdiction.
 - 1. Critical Radiant Flux (CRF): Not less than 0.45 watts per sq. cm. per ASTM E 648.
 - 2. Flame Spread: Not more than 75 per ASTM E 84.
 - 3. Smoke Developed: Not more than 450 per ASTM E 84.
 - 4. Smoke Density: Not more than 450 per ASTM E 662.

1.04 SUBMITTALS:

- A. Product Data:
 - 1. For information only, submit PDF copy of manufacturer's technical data and installation instructions for each type of resilient flooring and accessory. Transmit a copy of each installation instruction to the Installer.

B. Samples:

1. Submit (3) three sets of samples of each type, color and finish of resilient flooring and accessory required. Provide full-size tile units and 6" long sample of accessory. Include full range of flooring color and pattern variation. Sample submittals will be reviewed for color, texture and pattern only. Compliance with all other requirements is the exclusive responsibility of the Contractor.

C. Maintenance:

1. Submit PDF copy of manufacturer's written instructions for recommended maintenance practices for each type of resilient flooring and accessories.

1.05 JOB CONDITIONS:

- A. Continuously heat areas to receive flooring to 70 degrees F. for at least 48 hours prior to installation, when project conditions are such that heating is required. Maintain 70 degrees F. temperature continuously during and after installation, as recommended by flooring manufacturer, but for not less than 48 hours.

1.06 EXTRA STOCK

- A. Deliver to the Owner, for use in future modifications, an extra stock of approximately 10% (min. one carton) of each color and pattern in each material installed under this Section, packaging each type of material separately, distinctly marked, and adequately protected against deterioration.

PART 2 - PRODUCTS

2.01 TILE FLOORING: (LVT Flooring)

- A. Mannington Commercial Amtico Signature Collection/Wood:
(Basis of Design)
 1. Sizes: 6" x 36"
 2. Thickness: 0.098"
 3. Finish: Non-ortho phthalate
 4. Edge Treatment: Micro bevel or unbeveled
 5. Static Load: ASTM F970-passes, 2000 psi, residual indent \leq 0.005"
 6. Slip Resistance: ASTM C1028: passes \geq 0.5 leather, 0.6 rubber

7. 25 year limited commercial wear warranty
8. Recyclability: Contains 3% rapidly renewable resource content
9. Wear Layer: 40 mil (quantum guard elite)
10. Contact: Aaron Brown 734-853-7390
11. ASTM F1700 Class III, Type 'B'.
12. Size: Lay 6" x 36" planks in a staggered patten with arrows in same direction.
13. Color: To be selected by Architect.
14. Adhesive: Antico RP-18 full spread, one component.

2.02 ACCESSORIES:

A. Resilient Base:

1. Provide vinyl base (Johnsonite vinyl wall base CB) complying with ASTM F-1861, Type TV, Group 1 (solid) in all areas except Admin. Areas and Media Center unless noted otherwise, as follows:
 - a. Height: 4" - refer to drawings for locations.
 - b. Thickness: 1/8"
 - c. Style: Standard top-set cove or straight type as indicated.
 - d. Provide with preformed inside and outside colors.
 - e. ~~Provide with quarter round .5" high x .5" wide QTR-XX-A by Johnsonite at all interior door frames.~~
 - f. Install per manufacturers specs to maintain warranty.
 - g. Color: As selected by Architect.

B. Resilient Moulding/Reducer/Floor Finishing Accessories:

1. Provide vinyl nosings for resilient floor covering reducer strip for resilient floor covering, joiner for tile and carpet, or at junction between two dissimilar materials (new/new or new/existing), where shown on drawings and/or required.
 - a. Provide accessories as manufactured by Johnsonite, as follows:
 1. Carpet to LVT: CTA-XX-D
 2. Painted or sealed concrete to LVT: EG-XX-J 3/16" to floor
 - b. Color to be determined by Architect from manufacturer's standard colors.
 - c. Install per manufacturer's standard specifications to maintain warranty.

- C. Adhesives (cements): As recommended by flooring contractor to suit material and substrate conditions.
- D. Concrete Slab Primer: Non-staining type as recommended by flooring manufacturer.

PART 3 - EXECUTION

3.01 INSPECTION:

- A. Installer must examine the areas and conditions under which resilient flooring and accessories are to be installed and notify the General Contractor, in writing, of conditions detrimental to the proper and timely completion of the work. Do not proceed with the work until unsatisfactory conditions have been corrected in a manner acceptable to the Installer.

3.02 PREPARATION:

- A. Prior to laying flooring, broom clean or vacuum surfaces to be covered and inspect subfloor. Start of flooring installation indicates acceptance of subfloor conditions and full responsibility for completed work.
 - 1. Use leveling compound as recommended by flooring manufacturer for filling small cracks and depressions in subfloors.
 - 2. Perform moisture tests on concrete slabs to determine that concrete surfaces are sufficiently cured and ready to receive flooring.
 - 3. Apply concrete slab primer, if recommended by flooring manufacturer, prior to application of adhesive. Apply in compliance with manufacturer's directions.

3.03 INSTALLATION:

- A. General:
 - 1. Install flooring after finishing operations, including painting, have been completed and permanent heating system is operating. Moisture content of concrete slabs, building air temperature, and relative humidity must be within limits recommended by flooring manufacturer.

2. Place flooring with adhesive cement in strict compliance with manufacturer's recommendations. Butt tightly to vertical surfaces, thresholds, nosing and edgings. Scribe around obstructions and produce neat joints, laid tight, even and straight. Extend flooring into toe spaces, door reveals and into closets and similar openings.
3. Maintain reference markers, holes or openings that are in place or plainly marked for future cutting by repeating on finish flooring as marked on subfloor. Use chalk or other non-permanent marking device.
4. Maintain overall continuity of color and pattern with pieces of flooring installed in these covers. Tightly cement edges to perimeter of floor around covers and to covers.
5. Tightly cement flooring to subbase without open cracks, voids, raising and puckering at joints, telegraphing of adhesive spreader marks or other surface imperfections.

B. Tile Floors:

1. Lay tile from center marks established with principal walls, discounting minor offsets, so that tile at opposite edges of the room are of equal width. Adjust as necessary to avoid use of cut widths less than 1/2 tile at room perimeters. Lay tile square to room axis, unless otherwise shown.
2. Match tiles for color and pattern by using tile from cartons in same sequence as manufactured and packaged. Cut tile neatly to around all fixtures. Broken, cracked, chipped or deformed tile are not acceptable.

C. Accessories:

1. Apply resilient base to walls, columns, pilasters, casework and other permanent fixtures in rooms or areas where base is required. Install base in as long lengths as practicable, with preformed corner units or fabricated from base materials with mitered or coped inside corners. Tightly bond base to backing throughout the length of each piece, with continuous contact at horizontal and vertical surfaces.
 - a. On masonry surfaces or other similar irregular surfaces, fill voids along top edge of resilient wall base with manufacturer's recommended adhesive filler material.

2. Place resilient edge strips tightly butted to flooring and secure with adhesive. Install edging strips at all unprotected edges of flooring, unless otherwise shown.
3. Apply resilient accessories as indicated and in strict conformance to manufacturer's installation instructions.

3.04 CLEANING AND PROTECTION:

- A. Remove any excess adhesive or other surface blemishes, using neutral type cleaners as recommended by flooring manufacturer. Protect installed flooring from damage by covering.
- B. Finishing: After completion of project and just prior to final inspection of work, thoroughly clean floors and accessories.
- C. Apply sealer/polish as recommended by LVT manufacturer. Apply per manufacturers specifications (min. 3-4 coats of floor finish).

END OF SECTION 09650

SECTION 09970 - HIGH PERFORMANCE COATING SYSTEMS

COATINGS PART 1 - GENERAL

1.1 SECTION INCLUDES

- A. Epoxy Coating systems for the Clemens Center: exterior steel, interior steel columns, HM frames. Note: Multiple colors will be used in individual areas.

1.2 REFERENCES

- A. ASTM D 16 - Terminology Relating to Paint, Varnish, Lacquer and Related Products.
- B. SSPC-SP 2 - Hand Tool Cleaning.
- C. SSPC-SP 3 - Power Tool Cleaning.
- D. SSPC-SP 6/NACE 3 - Commercial Blast Cleaning.
- E. SSPC-SP 11 - Power Tool Cleaning to bare metal.
- F. SSPC-SP 13/NACE 6 Surface Preparation of Concrete
- G. ICRI - Concrete Surface Preparation Standards

1.3 DEFINITIONS

- A. Definitions of Painting Terms: ASTM D 16, unless otherwise specified.
- B. Dry Film Thickness (DFT): Thickness of a coat of paint in fully cured state measured in mils (1/1000 inch).
- C. Concrete Surface Standard (CSP): Standard for roughness of the surface profile of the concrete measured 1-9 with 9 being the roughest measured with a visual mold.

1.4 SUBMITTALS

- A. Comply with Section 01340 - "Shop Drawings, Product Data and Samples".
- B. Product Data: Submit manufacturer's product data for each coating, including generic description, complete technical data, surface preparation and application instructions.
- C. Color Samples: Submit manufacturer's color samples showing full range of standard colors.
- D. Manufacturer's Quality Assurance: Submit manufacturer's certification that coatings comply with specified requirements and are suitable for intended application.
- E. Applicator's Quality Assurance: Submit list of a minimum of 5 completed projects of similar size and complexity to this Work. Include for each project:
 - 1. Project name and location.
 - 2. Name of owner.
 - 3. Name of contractor.
 - 4. Name of architect.
 - 5. Name of coating manufacturer.
 - 6. Approximate area of coatings applied.
 - 7. Date of completion.
- F. Warranty: Submit manufacturer's standard warranty.

1.5 QUALITY ASSURANCE

- A. Manufacturer's Qualifications:
 - 1. Specialize in manufacture of coatings with a minimum of (10) years successful experience.
 - 2. Able to demonstrate successful performance on comparable projects.
 - 3. Single Source Responsibility: Coatings and coating application accessories shall be products of a single manufacturer.

B. Applicator's Qualifications:

1. Experienced in application of specified coatings for a minimum of (5) five years on projects of similar size and complexity to this Work.
2. Applicator's Personnel: Employ persons trained for application of specified coatings.

C. Preapplication Meeting: Convene a pre-application meeting (2) two weeks before start of application of coating systems. Require attendance of Construction Manager, Architect, applicator and manufacturer's representative. Review the following:

1. Environmental requirements.
2. Protection of surfaces not scheduled to be coated.
3. Surface preparation.
4. Application.
5. Repair.
6. Field quality control.
7. Cleaning.
8. Protection of coating systems.
9. One-year inspection.
10. Coordination with other work.

1.6 DELIVERY, STORAGE, AND HANDLING

A. Delivery: Deliver materials to site in manufacturer's original, unopened containers and packaging, with labels clearly identifying:

1. Coating or material name.
2. Manufacturer.
3. Color name and number.
4. Batch or lot number.
5. Date of manufacture.
6. Mixing and thinning instructions.

B. Storage:

1. Store materials in a clean dry area and within temperature range in accordance with manufacturer's instructions.
2. Keep containers sealed until ready for use.
3. Do not use materials beyond manufacturer's shelf life limits.

- C. Handling: Protect materials during handling and application to prevent damage or contamination.

1.7 ENVIRONMENTAL REQUIREMENTS

A. Weather:

1. Air and Surface Temperatures: Prepare surfaces and apply and cure coatings within air and surface temperature range in accordance with manufacturer's instructions.
2. Surface Temperature: Minimum of 5 degrees F (3 degrees C) above dew point.
3. Relative Humidity: Prepare surfaces and apply and cure coatings within relative humidity range in accordance with manufacturer's instructions.
4. Precipitation: Do not prepare surfaces or apply coatings in rain, snow, fog or mist.
5. Wind: Do not spray coatings if wind velocity is above manufacturer's limit.

- B. Ventilation: Provide ventilation during coating evaporation stage in confined or enclosed areas in accordance with manufacturer's instructions.

C. Dust and Contaminants:

1. Schedule coating work to avoid excessive dust and airborne contaminants.
2. Protect work areas from excessive dust and airborne contaminants during coating application and curing.

PART 2 PRODUCTS

2.1 MANUFACTURER

- A. PPG High Performance Coatings, 23361 Telegraph Road, Southfield, MI 48034 Contact: Robert Zaleski, Phone: (734) 564-3105. Web Site: www.ppghpc.com
- B. Tnemec Company Incorporated, 6800 Corporate Drive, Kansas City, Missouri 64120-1372. Toll Free (800) 863-6321. Phone (816) 483-3400. Fax (816) 483-3969. Web Site www.tnemec.com. Contact: Trent McNutt, cell (419)346-8795 office (614) 850-8160

2.2 INTERIOR STEEL (METAL DOORS, HOLLOW METAL FRAMES,
GRILLES, ETC.)

A. Chemical Exposure, Physical Abuse:

1. System Type: Modified aromatic polyurethane/waterborne epoxy-amine adduct/ceramic modified waterborne aliphatic polyurethane.
2. Surface Preparation: SSPC-SP 2/3 hand/power tool cleaning.

PPG

1. Prime Coat: 97-145 PITT-GUARD Direct-to-Rust Epoxy Mastic at 4.0 to 7.0 DFT
2. Intermediate Coat: AQUAPON WB 98E-1 Epoxy at 2.0 to 3.0 mils DFT.
3. Finish Coat: AQUAPON WB 98E-1 Epoxy at 2.0 to 3.0 mils DFT.

Tnemec

1. Prime Coat: Tnemec Series V69 Hi-Build Epoxoline II at 4.0 to 6.0 mils DFT.
2. Finish Coat: Tnemec Series 1095 Endura-Shield at 2.5 to 5.0 mils DFT.

2.3 PAINTED EXTERIOR EXPOSED STEEL

A. Chemical Exposure, Physical Abuse:

1. System Type: Surface Tolerant High Solids Epoxy / Polyester Acrylic Polyurethane System.
2. Surface Preparation: SSPC-SP 2 hand tool cleaning/SSPC-SP-3 power tool cleaning.

PPG - Lockshield System

1. Prime Coat: PPG Amerlock 2 High Solids Epoxy Coating at 4.0 to 8.0 mils DFT.
2. Intermediate Coat: PPG Amerlock 2 High Solids Epoxy Coating at 4.0 to 8.0 mils DFT.
3. Finish Coat: PPG Amershield VOC Polyester Acrylic Polyurethane at 3.0 to 5.0 mils DFT.

Tnemec

1. Prime Coat: Tnemec Series 1 Omnithane at 2.0 to 3.0 mils DFT.
2. Intermediate Coat: Series V69 Hi-Build Epoxoline II at 4.0- 6.0 mils DFT
3. Finish Coat: Tnemec Series 1094 Endura-Shield at 2.0-5.0 mils DFT

2.4A PAINTED EXPOSED INTERIOR STRUCTURAL STEEL

A. Atmospheric, Chemical, or UV Exposure, Physical Abuse:

1. System Type: Zinc-Rich Urethane/Polyamide Epoxy/waterborne aliphatic polyurethane.
2. Surface Preparation: SSPC-SP6 commercial blast cleaning.

PPG

1. Shop Primer: Durethane MCZ-97-699 at 2.0 to 4.0 mils DFT.
2. Field Intermediate Coat: Amercoat 385-multi-purpose epoxy at 4.0 to 6.0 mils DFT.
3. Field Finish Coat: Pitthane Ultra Urethane, 95-8800 at 2.0 to 3.0 mils DFT.

Tnemec

1. Shop Primer: Tnemec Series ~~AK01~~ **AK02** Tnemec Shop Primer at 2.0 to 3.0 mils DFT.
2. Field Intermediate Coat: Tnemec Series ~~48~~ **V69 Hi-Build Epoxoline II** at 4.0 to 6.0 mils DFT.
3. Field Finish Coat: Tnemec Series 1095 Endura Shield at 2.0 to 5.0 mils DFT.

2.4B COATING SYSTEMS FOR CONCRETE FLOORS (DECORATIVE CHIP)

A. Chemical Exposure, Physical Abuse:

1. System Type: Modified polyamine epoxy.
2. Surface Preparation: SSPC-SP 13/ICRI-CSP 3-5.

PPG

1. Prime Coat: MegaSeal HSPC 99-12700 at 8.0 to 10.0 mils
2. Intermediate Coat: MegaSeal SL 99-12600 15.0 to 20.0 mils DFT with complete broadcast to refusal of MegaSeal FLK decorative flake.
3. Finish Coat: MegaSeal SL 99-12600 10.0 to 20.0 mils DFT.

Tnemec

1. Surface Preparation: SSPC-SP 13/ICRI-CSP 3-5.
2. Prime Coat: Tnemec Series 237 Power-Tread at 8.0 to 10.0 mils DFT with complete broadcast to refusal of Tnemec Series 224C decorative flake.
3. Intermediate Coat: Tnemec Series 284 deco-clear at 10.0 to 20.0 mils DFT.
4. Finish Coat: Tnemec Series 248 Everthane at 2.0 to 3.0 mils DFT.

2.5 ACCESSORIES

- A. Coating Application Accessories:
 - 1. Accessories required for application of specified coatings in accordance with manufacturer's instructions, including thinners.
 - 2. Products of coating manufacturer.

PART 3 EXECUTION

3.1 EXAMINATION

- A. Examine areas and conditions under which coating systems are to be applied. Notify the General Contractor in writing of areas or conditions not acceptable. Do not begin surface preparation or application until unacceptable areas or conditions have been corrected.

3.2 PROTECTION OF SURFACES NOT SCHEDULED TO BE COATED

- A. Protect surrounding areas and surfaces not scheduled to be coated from damage during surface preparation and application of coatings.
- B. Immediately remove coatings that fall on surrounding areas and surfaces not scheduled to be coated.

3.3 SURFACE PREPARATION OF STEEL

- A. Prepare steel surfaces in accordance with manufacturer's instructions.
- B. Fabrication Defects:
 - 1. Correct steel and fabrication defects revealed by surface preparation.
 - 2. Remove weld spatter and slag.
 - 3. Round sharp edges and corners of welds to a smooth contour.
 - 4. Smooth weld undercuts and recesses.
 - 5. Grind down porous welds to pinhole-free metal.
 - 6. Remove weld flux from surface.
- C. Ensure surfaces are dry.
- D. Interior Steel Surfaces, Moderate to Severe Exposure: Remove

visible oil, grease, dirt, dust, mill scale, rust, paint, oxides, corrosion products and other foreign matter in accordance with SSPC- SP6.

- E. Abrasive Blast-Cleaned Surfaces: Coat abrasive blast-cleaned surfaces with primer before visible rust forms on surface. Do not leave blast-cleaned surfaces uncoated for more than 8 hours.
- F. Primer: Prepare field primer to receive field coat in accordance with manufacturer's instructions.

3.4 APPLICATION

- A. Apply coatings in accordance with manufacturer's instructions.
- B. Mix and thin coatings, including multi-component materials, in accordance with manufacturer's instructions.
- C. Keep containers closed when not in use to avoid contamination.
- D. Do not use mixed coatings beyond pot life limits.
- E. Use application equipment, tools, pressure settings and techniques in accordance with manufacturer's instructions.
- F. Uniformly apply coatings at spreading rate required to achieve specified DFT.
- G. Apply coatings to be free of film characteristics or defects that would adversely affect performance or appearance of coating systems.
- H. Stripe paint with brush critical locations on steel such as welds, corners and edges using specified primer.

3.5 REPAIR

- A. Materials and Surfaces Not Scheduled to Be Coated: Repair or replace damaged materials and surfaces not scheduled to be

coated.

- B. Damaged Coatings: Touch-up or repair damaged coatings. Touch-up of minor damage shall be acceptable where result is not visibly different from adjacent surfaces. Recoat entire surface where touch-up result is visibly different, either in sheen, texture or color.
- C. Coating Defects: Repair in accordance with manufacturer's instructions coatings that exhibit film characteristics or defects that would adversely affect performance or appearance of coating systems.

3.6 FIELD QUALITY CONTROL

- A. Inspector's Services:
 - 1. Verify coatings and other materials are as specified.
 - 2. Verify surface preparation and application are as specified.
 - 3. Verify DFT of each coat and total DFT of each coating system are as specified using wet film and dry film gauges.
 - 4. Coating Defects: Check coatings for film characteristics or defects that would adversely affect performance or appearance of coating systems.
 - a. Check for holidays on interior steel immersion surfaces using holiday detector.
 - 5. Report:
 - a. Submit written reports describing inspections made and actions taken to correct nonconforming work.
 - b. Report nonconforming work not corrected.
 - c. Submit copies of report to Architect, Owner's Representative and Construction Manager.
- B. Manufacturer's Field Services: Manufacturer's representative shall provide technical assistance and guidance for surface preparation and application of coating systems.

3.7 CLEANING

- A. Remove temporary coverings and protection of surrounding areas and surfaces.

3.8 PROTECTION OF COATING SYSTEMS

- A. Protect surfaces of coating systems from damage during construction.

3.9 ONE-YEAR INSPECTION

- A. Owner will set date for one-year inspection of coating systems.
- B. Inspection shall be attended by Owner, Contractor, Engineer/Architect and manufacturer's representative.
- C. Repair deficiencies in coating systems as determined by Architect in accordance with manufacturer's instructions.

END OF SECTION 09970

SECTION 12364 - QUARTZ SURFACES

PART 1 - GENERAL

1.01 DESCRIPTION

- A. Work described in this section:
 - 1. Countertops and Backsplashes.

- B. Related work specified elsewhere:
 - 1. Section 06100 - Carpentry
 - 2. Section 06402 - Interior Architectural
Woodwork

1.02 REFERENCES

- A. Applicable Standards: Standards of the following,
as referenced herein:
 - 1. American National Standards Institute (ANSI)
 - 2. American Society for Testing and Materials
(ASTM)
 - 3. National Electrical Manufacturers
Association (NEMA)
 - 4. Federal Specifications (FS)

1.03 SUBMITTALS

- A. Shop drawings: Indicate dimensions, component
sizes, fabrication details, attachment provisions
and coordination requirements with adjacent work.

- B. Samples: Submit minimum 2" x 2" (50mm x 50mm)
samples. Indicate full range of color and pattern
variation. Approved samples will be retained as
standards for work.

- C. Product data: Indicate product description,
fabrication information and compliance with
specified performance requirements.

- D. Maintenance data: Submit manufacturer's care and
maintenance data, including repair and cleaning
instructions. Include in project close-out
documents.

1.04 QUALITY ASSURANCE

- A. Allowable tolerances:
 - 1. Variation in component size: $\pm 1/8''$ (3 mm).
 - 2. Location of openings: $\pm 1/8''$ (3 mm) from indicated location.

1.05 DELIVERY, STORAGE AND HANDLING

- A. Deliver no components to project site until areas are ready for installation. Store components indoors prior to installation.
- B. Handle materials to prevent damage to finished surfaces. Provide protective coverings to prevent physical damage or staining following installation for duration of project.

1.06 WARRANTY

- A. Provide manufacturer's (10) ten year standard warranty against defects in materials. Warranty shall provide material and labor to repair or replace defective materials. Damage caused by physical or chemical abuse or damage from excessive heat will not be warranted.

PART 2 - PRODUCTS

2.01 SOLID POLYMER FABRICATIONS

- A. Material: Quartz material composed of approximately 93% natural quartz with pigments and resins .

Performance/Design Criteria:

- 1. Flexural Strength $> 5,300$ psi ASTM D790
- 2. Flexural Modulus 5.3-5.7 X 10⁶ psi ASTM D790
- 3. Compression Strength (Dry) 27,300 psi ASTM C170
- 4. Compression Strength (Wet) 24,400 psi ASTM C170
- 5. Hardness 7 Mohs Hardness Scale
- 6. Thermal Expansion 1.45 x 10⁻⁵ meter/meter deg C
ASTM D696
- 7. Thermal Expansion 2.61 x 10⁻⁵ inch/inch deg F
ASTM D696

8. Colorfastness Passes NEMA LD 3-3.3
9. Gloss (60° Gardner) 45-50 ANSI Z124
10. Wear and Cleanability Passes CSA B45.5-11/IAPMO Z124-2011
11. Stain Resistance Passes CSA B45.5-11/IAPMO Z124-2011
12. Fungal Resistance No observed growth on product ASTM G 21
13. Bacterial Resistance No observed growth on product ASTM G 22
14. High Temperature Resistance None to slight effect NEMA LD 3-3.6
 - a. Temperature, 356 deg F
15. Boiling Water Resistance None to slight effect NEMA LD 3-3.5
16. Freeze-Thaw Cycling Unaffected ASTM C1026
17. Point Impact Passes ANSI Z124.6.4.2
18. Ball Impact Resistance No failure at 164 inches NEMA LD 3-3.8
 - a. Slabs, No fracture, 1/2 lb. ball-2cm and 3 cm
19. Static Coefficient of Friction 0.89 (Dry), 0.61 (Wet) ASTM C1028
20. Abrasion Resistance 139 ASTM C501
21. Density 2.4 g/cm³ ASTM D792
22. Water Absorption, Long-term 0.12% ASTM C373
23. Water Absorption, Short < 0.04% ASTM C373
24. Moisture Expansion < 0.01% average ASTM C370
25. Flammability Class A, all colors NFPA 101® Life Safety Code
26. Flame Spread Index FSI 0 for 3 cm UL 723
27. Flame Spread Index FSI ≤ 5 for 2 cm UL 723
28. Smoke Developed Index SDI ≤ 40 for 3 cm UL 723
29. Smoke Developed Index SDI ≤ 75 for 2 cm UL 723
30. Flame Spread Value 0 for 3 cm CAN/ULC-S102
31. Flame Spread Value 5 for 2 cm CAN/ULC-S102
32. Smoke Developed Value 10 for 3 cm CAN/ULC-S102
33. Smoke Developed Value 50 for 2 cm CAN/ULC S102
34. Nominal Thickness 2 cm and 3 cm
35. Nominal Weight per square foot for 2cm thickness is 10 pounds
36. Nominal Weight per square foot for 3cm thickness is 15 pounds

- B. Manufacturer:
 - 1. Corian Quartz (formerly known as Zodiaq)
(Basis of Design)
 - 2. Cambria
 - 3. Silestone
 - 4. Wilsonart
 - 5. Caesarstone

- C. Windowsills: 3/4" thick solid quartz material, as shown on drawings, adhesively joined with recommended seam widths not greater than 3mm in finished work; edge details as indicated on the Architects drawings.

- D. Countertops & Backsplash: 1-1/8" thick (as shown on drawings) countertop of solid quartz surfacing material, cast adhesively joined with inconspicuous seams (max 1/16"); edge details as indicated on the Architects drawings.

2.02 ACCESSORY PRODUCTS

- A. Seam adhesive: Manufacturer's standard adhesive to create inconspicuous, non-porous color coordinated joints, with a chemical bond.

- B. Mounting Adhesive: 100 percent silicone sealant.

2.03 FABRICATION

- A. Fabricate components in shop to greatest extent practical to sizes and shapes indicated, in accordance with approved shop drawings and manufacturer's requirements. Provide factory cutouts for plumbing fittings as indicated on drawings.

- B. Form joints between components using manufacturer's standard joint adhesive. Joints shall be inconspicuous in appearance and without voids.

- C. Rout and finish component edges to a smooth, uniform finish. Rout all cutouts, then sand all edges smooth. Repair or reject defective or inaccurate work.
- D. Finish: All surfaces shall have uniform finish.
 - 1. Gloss rating >45.
- E. Fabrication Tolerances:
 - 1. Variation in component size: +/- 3mm (+/- 1-1/8")
 - 2. Location of openings: +/- 3mm (+/- 1-1/8").
- F. Finishes:
 - 1. Quartz-1: Corian quartz in color: To be selected from all use groups.

PART 3 - EXECUTION

3.01 JOB MOCK-UP

- A. Prior to final approval of shop drawings, erect a 1' x 2' size mock-up of each component at project site for Architect review.
- B. Should mock-up not be approved, rework or remake until approval is secured. Remove rejected units from project site.

3.02 INSTALLATION

- A. Install components plumb, level, rigid, scribed to adjacent finishes, in accordance with approved shop drawings and product installation details.
- B. Fabricate field joints using manufacturer's recommended adhesive, with joints inconspicuous in finished work. Keep components and hands clean when making joints.

- C. Keep components and hands clean during installation. Remove adhesives, sealants and other stains. Components shall be clean on Date of Substantial Completion.
- D. Route radii and contours to template. Anchor securely to base component or other supports. Align adjacent components and form seams to comply with manufacturer's written recommendations using adhesive in color to match work. Carefully dress joints smooth, remove surface scratches and clean entire surface.
- E. Install countertops with no more than 3 mm (1/8") sag, bow or other variation from a straight line.
- F. Adhere topmount and/or undermount sinks/bowls to countertops using manufacturer's recommended adhesives and color-matched silicone sealant and mounting hardware. Secure seam mount bowls and sinks to countertops using color matched joint adhesive.
- G. Seal between wall and components with joint sealant as specified herein and in Section 07920 "Sealants and Caulking".
- H. Provide backsplashes and end splashes as indicated on Drawings. Adhere to countertops using a standard color-coordinated silicone sealant. Adhere applied side splashes to countertops using a standard color-coordinated silicone sealant.
- I. Coordinate electrical fixtures and connections in accordance with Division 16 "Electrical".
- J. Protect surfaces from damage until Date of Substantial Completion. Repair or replace damaged work that cannot be repaired to Architect's satisfaction.

MACOMB COUNTY
CLEMENS CENTER

COUNTY CLERK STORAGE RENOV.

231987

JULY 25, 2024

- K. Fabricator/Installer is to provide manufacturers recommended manuals, and review maintenance procedures and the manufacturer's warranty with the head of Maintenance upon completion of the project.

END OF SECTION 12364

MACOMB COUNTY BOARD OF COMMISSIONERS

CLEMENS CENTER - COUNTY CLERK STORAGE RENOVATION

ISSUED FOR: CONSTRUCTION DOCUMENTS
 DATE: July 25, 2024 (ADDENDUM #1 August 09,2024)
 PROJECT NO.: 231987

ARCHITECT:

WAKELY ASSOCIATES, INC./ ARCHITECTS
 30500 VAN DYKE AVE, SUITE 209, WARREN, MI 48093, 586-573-4100

MECHANICAL/ ELECTRICAL ENGINEERS:

 UNIFIED BUILDING SYSTEMS ENGINEERING, LLC
 75 N. MAIN ST. SUITE 221, MT. CLEMENS, MI 48043, 248.804.1741

Index of Drawings	
ARCHITECTURAL DRAWINGS:	
G0.0	COVER SHEET
G4.1	GENERAL INFORMATION, SYMBOLS AND ABBREVIATIONS
A1.0	COMPOSITE FLOOR PLANS
A1.1	CLEMENS CENTER - ENLARGED DEMOLITION AND NEW WORK FLOOR PLANS
A1.2	CLEMENS CENTER - ENLARGED REFLECTED CEILING AND ROOF PLANS
MECHANICAL DRAWINGS:	
M10.00	CLEMENS CENTER - MECHANICAL GENERAL INFORMATION
MD1.00	CLEMENS CENTER - MECHANICAL DEMOLITION LOWER LEVEL FLOOR PLAN
P1.00	CLEMENS CENTER - PLUMBING NEW WORK LOWER LEVEL FLOOR PLAN
M1.00	CLEMENS CENTER - MECHANICAL NEW WORK LOWER LEVEL FLOOR PLAN
M15.00	CLEMENS CENTER - MECHANICAL DETAILS AND SCHEDULES
ELECTRICAL DRAWINGS:	
E10.00	CLEMENS CENTER - ELECTRICAL GENERAL INFORMATION AND LIGHTING SCHEDULE
EPD1.00	CLEMENS CENTER - POWER DEMOLITION LOWER LEVEL FLOOR PLAN
ELD1.00	CLEMENS CENTER - LIGHTING DEMOLITION LOWER LEVEL FLOOR PLAN
EPT1.00	CLEMENS CENTER - POWER NEW WORK LOWER LEVEL FLOOR PLAN
EL1.00	CLEMENS CENTER - LIGHTING NEW WORK LOWER LEVEL FLOOR PLAN
E15.00	CLEMENS CENTER - ELECTRICAL DETAILS AND PANEL SCHEDULES
E16.00	CLEMENS CENTER - ELECTRICAL ONE LINE DIAGRAM

Location Map

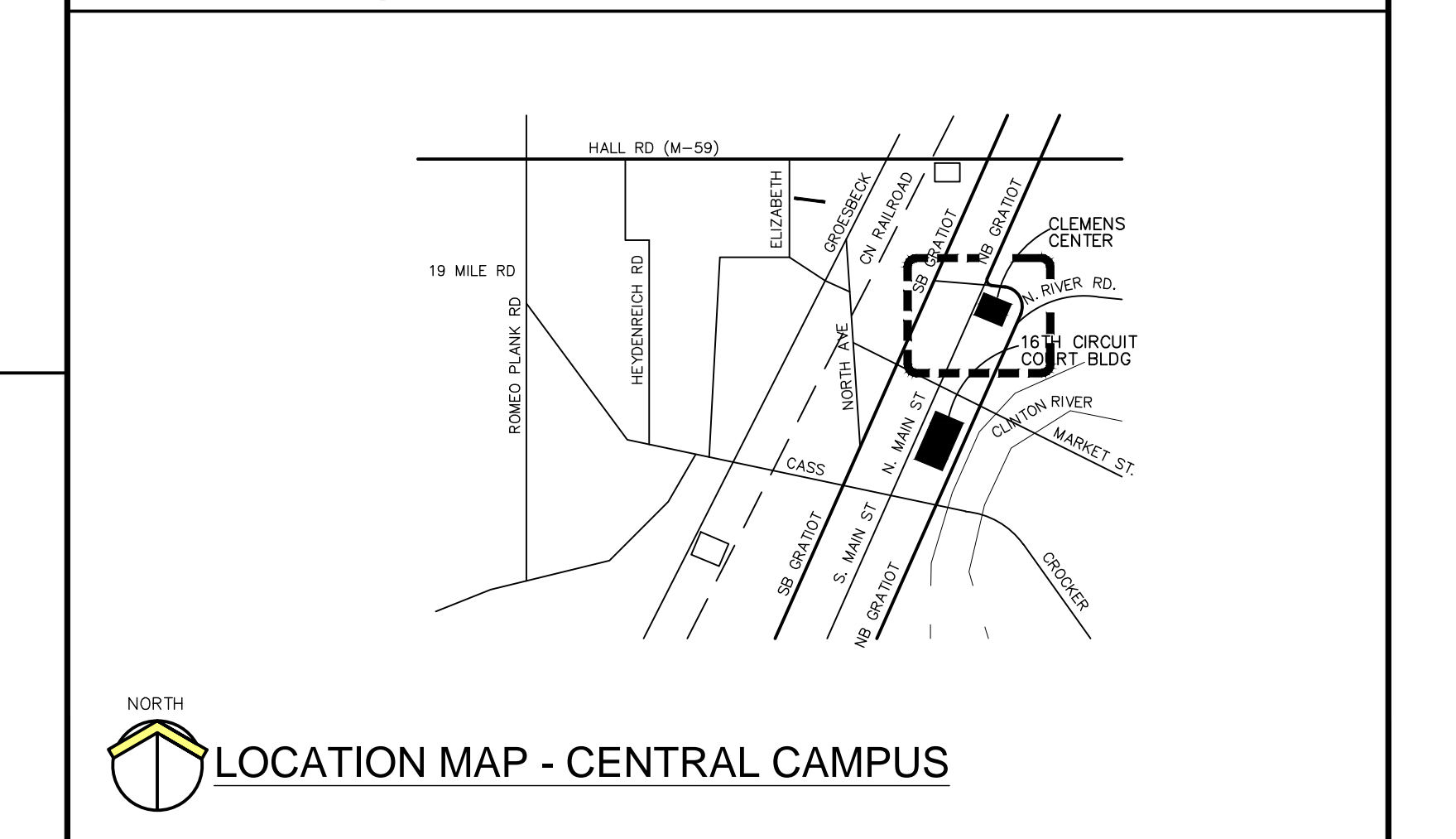

<p>ENGINEER SEAL:</p>	<p>ARCHITECT SEAL:</p>
-----------------------	------------------------

NO.	ROOM NAME	FLOOR	BASE	WALLS				CEILING		REMARKS
				NORTH	SOUTH	WEST	EAST	MAT'L	HGT.	
A100	F+O STORAGE	EP	4RB	GB-PT	ETR-PT	ETR-PT	GB-PT	ACT-1	9'-0"	1,2,3,4,6,7
A101	OFFICE	CPT	4RB	GB-PT	ETR-PT	ETR-PT	GB-PT	ACT-1	9'-0"	1,2,3,4,6,7
A102	CORRIDOR	LVT	4RB	GB-PT	ETR-PT	ETR-PT	GB-PT	ACT-1	9'-0"	1,2,3,4,6,7
A103	SECURED STORAGE	LVT	4RB	GB-PT	ETR-PT	GB-PT	ETR-PT	ACT-1	9'-0"	1,2,3,4,6,7
A104	HIGH-DENSITY STORAGE	EP/LVT	4RB	GB-PT	ETR-PT	ETR-PT	ETR-PT	--	--	1,2,3,4,5,6,7
A105	NEW CLERK STORAGE	LVT	4RB	ETR-PT	GB-PT	ETR-PT	ETR-PT	--	9'-0"	1,2,4

NO.	DOOR OPENING		DOOR		FRAME		DETAILS						REMARKS	
	WIDTH	HEIGHT	TYPE	MATERIAL	FINISH	TYPE	MATERIAL	FINISH	HEAD	JAMB	SILL	THRESHOLD		U.L. LABEL
FIRST FLOOR														
A100	3'-0"	7'-0"	F	WD	STN	1	HM	PT	H2	J2	-	-	-	3
A101	3'-0"	7'-0"	N	WD	STN	1	HM	PT	H2	J2	-	-	-	1,3
A102	3'-0"	7'-0"	N	WD	STN	1	HM	PT	H2	J2	-	-	20MIN.	1,3
A103	3'-0"	7'-0"	F	WD	STN	1	HM	PT	H2	J2	-	-	-	3
A104	2 @ 3'-0"	7'-0"	F	HM	PT	2	HM	PT	H1	J1	-	-	AL	2,3

DOOR SCHEDULE REMARKS

- ALL INTERIOR GLASS TO BE 1/4" LAMINATED GLASS, U.N.O.
- ALTERNATE NO. 2: PROVIDE FRP DOORS AND ALUMINUM FRAME IN LIEU OF HOLLOW METAL. REFER TO SPECS.
- PAINT ALL HOLLOW METAL DOOR AND FRAMES EPOXY PAINT.

FRAME TYPES

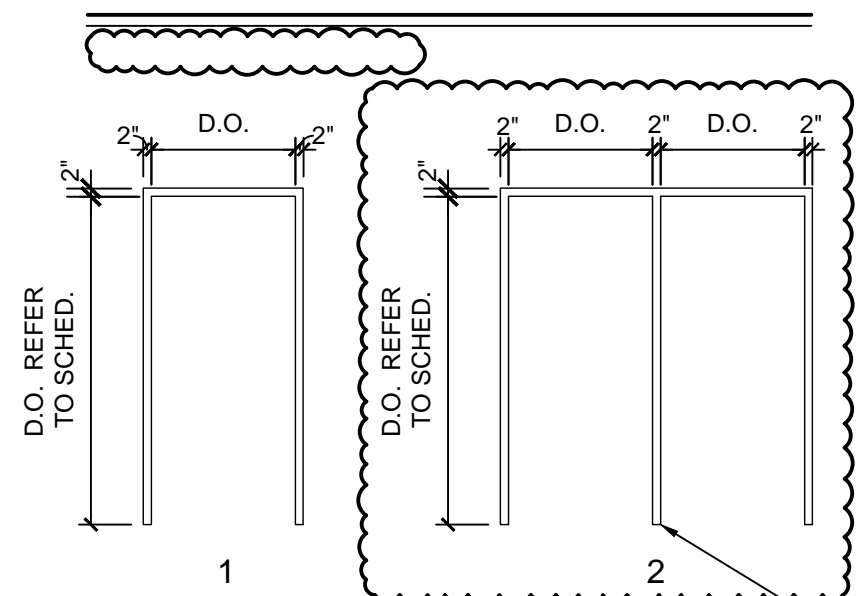

DOOR ELEVATIONS

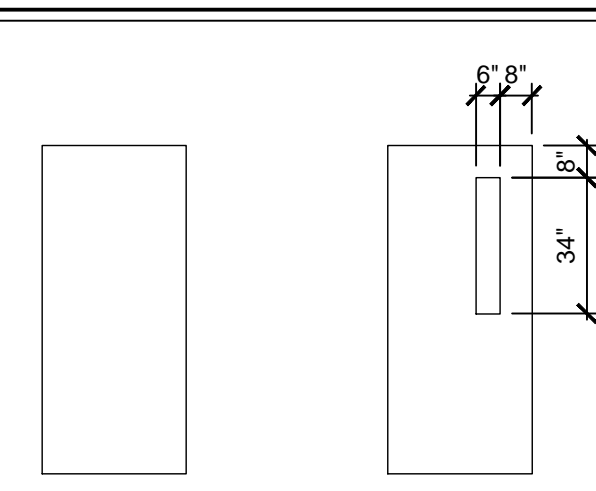

ABBREVIATIONS:

ACT	ACOUSTICAL CEILING TILE IN METAL GRID
CPT	CARPET - SEE SPECIFICATIONS
ETR	EXISTING TO REMAIN
GB	GYP. BOARD (WALLS ONLY TO BE HI-IMPACT GYPSUM BOARD)
LVT	LUXURY VINYL TILE
RB	4" RESILIENT BASE
EP	EPOXY FLOORING

ROOM FINISH NOTES

- PAINT ALL EXISTING WALLS IN NEW WORK AREA.
- ALL WALL BOARD TO BE ABUSE RESISTANT GYPSUM BOARD.
- ALL EXISTING AND NEW GYPSUM BOARD WALL CORNERS TO HAVE STAINLESS STEEL CORNER GUARDS. REFER TO SPECS.
- RUN LVT THE LENGTH OF THE ROOM AT 1/3 OFFSET UNLESS OTHERWISE NOTED.
- EXPOSED CEILING - PAINT ALL EXPOSED STEEL JOIST, COLUMNS, PIPING, CONDUITS, DUCTWORK, ETC.
- PROVIDE TRANSITION AT FLOOR BETWEEN DISSIMILAR MATERIALS. REFER TO SPECS.
- PROVIDE STAINLESS STEEL CORNER GUARDS AT ALL NEW AND EXISTING GYPSUM BOARD WALLS. REFER TO SPECIFICATIONS.

NO.	ROOM NAME	QTY	TYPE	MOUNTING	TEXT
A100	F+O STORAGE	1	A	1	LINE 1: STORAGE
A101	OFFICE	1	A	1	LINE 1: OFFICE
A102	CORRIDOR	-	-	-	-
A103	SECURED STORAGE	1	A	1	LINE 1: STORAGE
A105	ALCOVE	1	A	1	LINE 1: STORAGE LINE 2: COUNTY CLERK LINE 3: STORAGE FACILITY

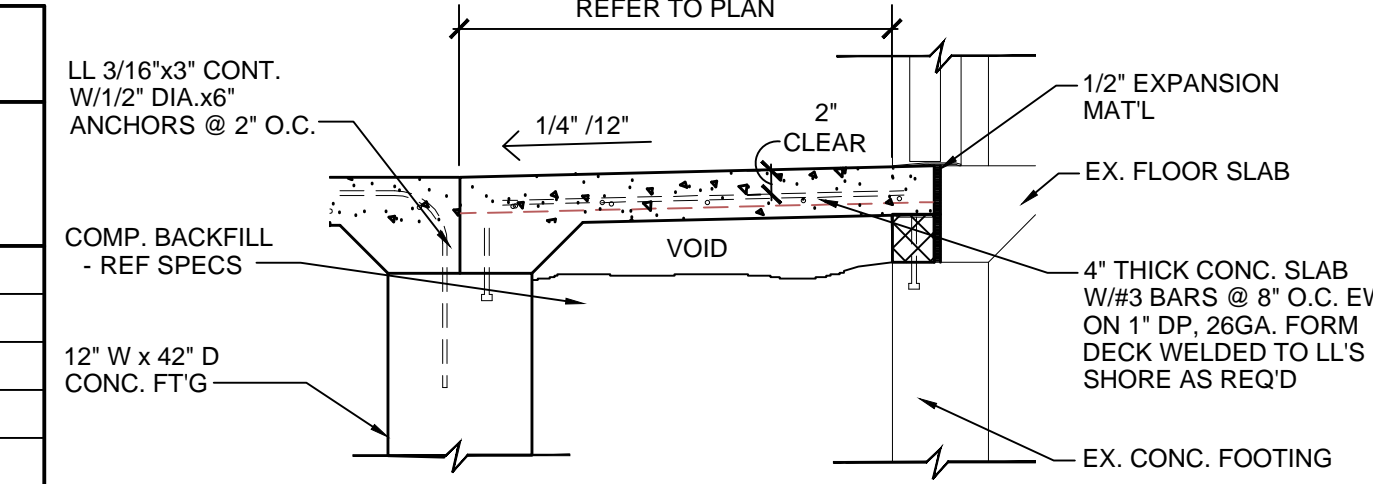
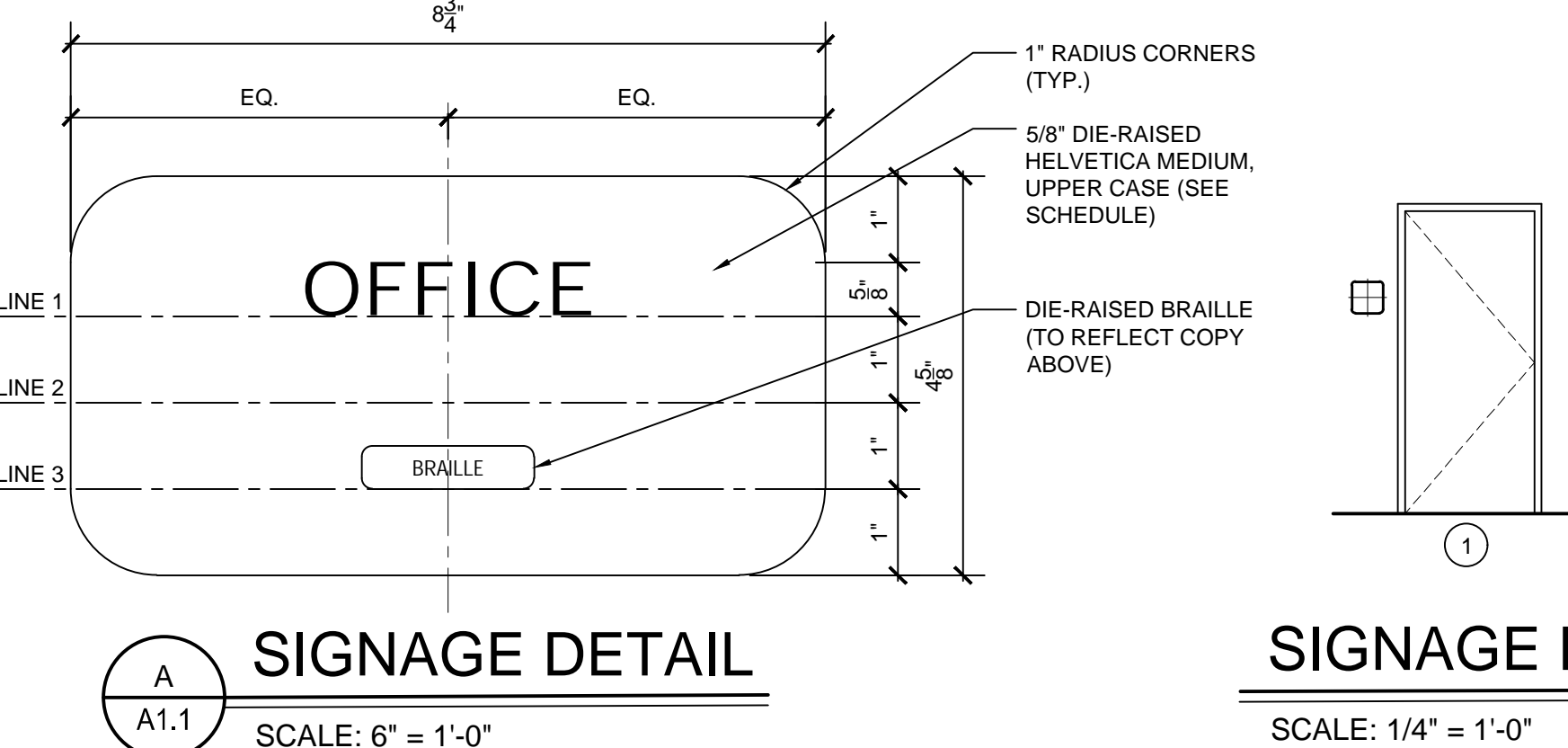

SECTION DETAIL - SUPPORTED SLAB

SCALE: 3/4" = 1'-0"

8 A1.1

NOTE: SIGN MOUNTING TYPICAL FOR OPPOSITE DOOR CONFIGURATION

SCALE: 1/4" = 1'-0"

SCALE: 6" = 1'-0"

SCALE: 1/4" = 1'-0"

SCALE: 6" = 1'-0"

SCALE: 1/4" = 1'-0"

SCALE: 6" = 1'-0"

SCALE: 1/4" = 1'-0"

SCALE: 6" = 1'-0"

SCALE: 1/4" = 1'-0"

SCALE: 6" = 1'-0"

SCALE: 1/4" = 1'-0"

SCALE: 6" = 1'-0"

SCALE: 1/4" = 1'-0"

SCALE: 6" = 1'-0"

SCALE: 1/4" = 1'-0"

SCALE: 6" = 1'-0"

SCALE: 1/4" = 1'-0"

SCALE: 6" = 1'-0"

SCALE: 1/4" = 1'-0"

SCALE: 6" = 1'-0"

SCALE: 1/4" = 1'-0"

SCALE: 6" = 1'-0"

SCALE: 1/4" = 1'-0"

SCALE: 6" = 1'-0"

SCALE: 1/4" = 1'-0"

SCALE: 6" = 1'-0"

SCALE: 1/4" = 1'-0"

SCALE: 6" = 1'-0"

SCALE: 1/4" = 1'-0"

SCALE: 6" = 1'-0"

SCALE: 1/4" = 1'-0"

SCALE: 6" = 1'-0"

SCALE: 1/4" = 1'-0"

SCALE: 6" = 1'-0"

SCALE: 1/4" = 1'-0"

SCALE: 6" = 1'-0"

SCALE: 1/4" = 1'-0"

SCALE: 6" = 1'-0"

SCALE: 1/4" = 1'-0"

SCALE: 6" = 1'-0"

SCALE: 1/4" = 1'-0"

SCALE: 6" = 1'-0"

SCALE: 1/4" = 1'-0"

SCALE: 6" = 1'-0"

SCALE: 1/4" = 1'-0"

SCALE: 6" = 1'-0"

SCALE: 1/4" = 1'-0"

SCALE: 6" = 1'-0"

SCALE: 1/4" = 1'-0"

SCALE: 6" = 1'-0"

SCALE: 1/4" = 1'-0"

SCALE: 6" = 1'-0"

SCALE: 1/4" = 1'-0"

SCALE: 6" = 1'-0"

SCALE: 1/4" = 1'-0"

SCALE: 6" = 1'-0"

SCALE: 1/4" = 1'-0"

SCALE: 6" = 1'-0"

SCALE: 1/4" = 1'-0"

SCALE: 6" = 1'-0"

SCALE: 1/4" = 1'-0"

SCALE: 6" = 1'-0"

SCALE: 1/4" = 1'-0"

SCALE: 6" = 1'-0"

SCALE: 1/4" = 1'-0"

SCALE: 6" = 1'-0"

SCALE: 1/4" = 1'-0"

SCALE: 6" = 1'-0"

SCALE: 1/4" = 1'-0"

SCALE: 6" = 1'-0"

SCALE: 1/4" = 1'-0"

SCALE: 6" = 1'-0"

SCALE: 1/4" = 1'-0"

SCALE: 6" = 1'-0"

SCALE: 1/4" = 1'-0"

SCALE: 6" = 1'-0"

SCALE: 1/4" = 1'-0"

SCALE: 6" = 1'-0"

SCALE: 1/4" = 1'-0"

SCALE: 6" = 1'-0"

SCALE: 1/4" = 1'-0"

SCALE: 6" = 1'-0"

SECTION DETAIL - RECESSED RAIL SYSTEM

SCALE: 6" = 1'-0"

SCALE: 1/4" = 1'-0"

SCALE: 6" = 1'-0"

SCALE: 1/4" = 1'-0"

SCALE: 6" = 1'-0"

SCALE: 1/4" = 1'-0"

SCALE: 6" = 1'-0"

SCALE: 1/4" = 1'-0"

SCALE: 6" = 1'-0"

SCALE: 1/4" = 1'-0"

SCALE: 6" = 1'-0"

SCALE: 1/4" = 1'-0"

SCALE: 6" = 1'-0"

SCALE: 1/4" = 1'-0"

SCALE: 6" = 1'-0"

SCALE: 1/4" = 1'-0"

SCALE: 6" = 1'-0"

SCALE: 1/4" = 1'-0"

SCALE: 6" = 1'-0"

SCALE: 1/4" = 1'-0"

SCALE: 6" = 1'-0"

SCALE: 1/4" = 1'-0"

SCALE: 6" = 1'-0"

SCALE: 1/4" = 1'-0"

SCALE: 6" = 1'-0"

SCALE: 1/4" = 1'-0"

SCALE: 6" = 1'-0"

SCALE: 1/4" = 1'-0"

SCALE: 6" = 1'-0"

SCALE: 1/4" = 1'-0"

SCALE: 6" = 1'-0"

SCALE: 1/4" = 1'-0"

SCALE: 6" = 1'-0"

SCALE: 1/4" = 1'-0"

SCALE: 6" = 1'-0"

SCALE: 1/4" = 1'-0"

SCALE: 6" = 1'-0"

SCALE: 1/4" = 1'-0"

SCALE: 6" = 1'-0"

SCALE: 1/4" = 1'-0"

SCALE: 6" = 1'-0"

SCALE: 1/4" = 1'-0"

SCALE: 6" = 1'-0"

SCALE: 1/4" = 1'-0"

SCALE: 6" = 1'-0"

SCALE: 1/4" = 1'-0"

SCALE: 6" = 1'-0"

SCALE: 1/4" = 1'-0"

SCALE: 6" = 1'-0"

SCALE: 1/4" = 1'-0"

SCALE: 6" = 1'-0"

SCALE: 1/4" = 1'-0"

SCALE: 6" = 1'-0"

SCALE: 1/4" = 1'-0"

SCALE: 6" = 1'-0"

SCALE: 1/4" = 1'-0"

SCALE: 6" = 1'-0"

SCALE: 1/4" = 1'-0"

SCALE: 6" = 1'-0"

SCALE: 1/4" = 1'-0"

SCALE: 6" = 1'-0"

SCALE: 1/4" = 1'-0"

SCALE: 6" = 1'-0"

SCALE: 1/4" = 1'-0"

SCALE: 6" = 1'-0"

SCALE: 1/4" = 1'-0"

SCALE: 6" = 1'-0"

SCALE: 1/4" = 1'-0"

SCALE: 6" = 1'-0"

SCALE: 1/4" = 1'-0"

SCALE: 6" = 1'-0"

SCALE: 1/4" = 1'-0"

SCALE: 6" = 1'-0"

SCALE: 1/4" = 1'-0"

SCALE: 6" = 1'-0"

SCALE: 1/4" = 1'-0"

SCALE: 6" = 1'-0"

SCALE: 1/4" = 1'-0"

SCALE: 6" = 1'-0"

SCALE: 1/4" = 1'-0"

SCALE: 6" = 1'-0"

SCALE: 1/4" = 1'-0"

SCALE: 6" = 1'-0"

SCALE: 1/4" = 1'-0"

SCALE: 6" = 1'-0"

DEMOLITION KEYNOTES

- REMOVE PORTION OF EXISTING WALL FOR NEW DOOR OPENING.
- REMOVE WALL (WOOD STUDS AND PLYWOOD) IN ITS ENTIRETY.
- REMOVE EXISTING DOOR, FRAME AND HARDWARE IN ITS ENTIRETY.
- REMOVE ALL EXISTING SHELVING AND RETURN TO OWNER. OWNER TO REMOVE ALL FILES PRIOR TO DEMOLITION.
- SAWCUT EXISTING CONCRETE SLAB FLOOR AS REQUIRED FOR NEW FLOOR DRAINS AND SANITARY LINES. REFER TO ELECT./MECH. DWGS. COORDINATE WITH TRADES FOR EXACT LOCATIONS.
- SAWCUT 12" W x 2"D. TRENCH FOR NEW HIGH-DENSITY RECESSED RAIL SYSTEM. REFER TO MANUFACTURER'S SPECIFICATIONS AND DETAIL 7A1.1.
- EXISTING BUSH, GRASS, SIGNAGE AND CONCRETE WALK TO REMAIN.
- EXISTING BRICK PAVEMENT BORDER TO BE REMOVED AND REINSTALLED AS SHOWN ON DRAWINGS. REMOVE EXISTING CONCRETE WALK AS REQUIRED FOR NEW SUPPORTED SLAB AT NEW DOOR.
- EXISTING GRASS AREA TO REMAIN. RESTORE AND RESEED AS REQUIRED.
- REMOVE EXISTING CURB AS SHOWN ON DRAWINGS.
- REMOVE EXISTING GRASS FOR CONCRETE WALKWAY.

NEW WORK FLOOR PLAN KEYNOTES

- NEW WALL PARTITION - REFER TO LEGEND.
- NEW DOOR, FRAME AND HARDWARE - REFER TO DOOR SCHEDULE. TOOTH-IN NEW BULLNOSE EDGE CMU (PAINT) AT BOTH JAMBS. PROVIDE NEW MASONRY. LINTEL WITH 8" MIN. BEARING.
- NEW QUARTZ COUNTER, BACKSPLASH AND BASE CABINETS. REFER TO INTERIOR ELEVATIONS.
- NEW FLOOR, WALL AND CEILING FINISHES. REFER TO ROOM FINISH SCHEDULE.
- NEW GYPSUM BOARD ENCLOSURE AT EXISTING COLUMN.
- HIGH-DENSITY STORAGE SYSTEM WITH SHELVING, LED LIGHTING, ETC. RAIL SYSTEM TO BE RECESSED INTO EXISTING CONCRETE FLOOR. REFER TO DEMOLITION PLAN, LEVEL FLOOR AS REQUIRED. REFER TO SPECIFICATIONS.
- PROVIDE NEW PARTITION ABOVE EXISTING WALL (TIGHT TO THE DECK).
- PATCH EXISTING CONCRETE SLAB AS REQUIRED FOR NEW FLOOR DRAINS/SANITARY LINE. REFER TO MECH. DWGS. COORDINATE WITH TRADES FOR EXACT LOCATION OF EXISTING SANITARY LINE.
- NEW AIR CONDITIONING UNIT. REFER TO MECH./ELECT. DWGS.
- INFILL NEW TRENCH FOR NEW HIGH-DENSITY STORAGE RECESSED RAIL SYSTEM PER THE MANUFACTURER'S SPECIFICATIONS.
- NEW 8'x4' MARKERBOARD. REFER TO

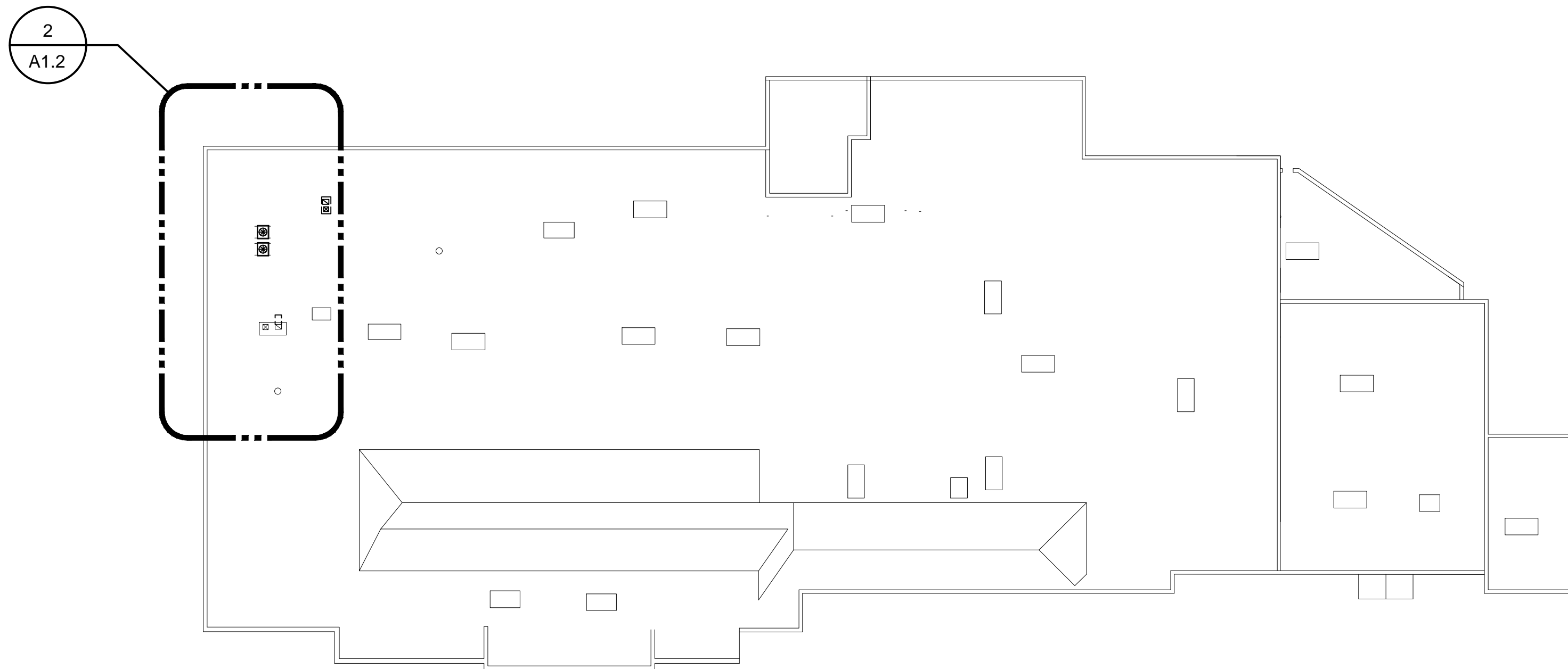

**CLEMENS CENTER
COMPOSITE ROOF PLAN**
SCALE: 1/32" = 1'-0"

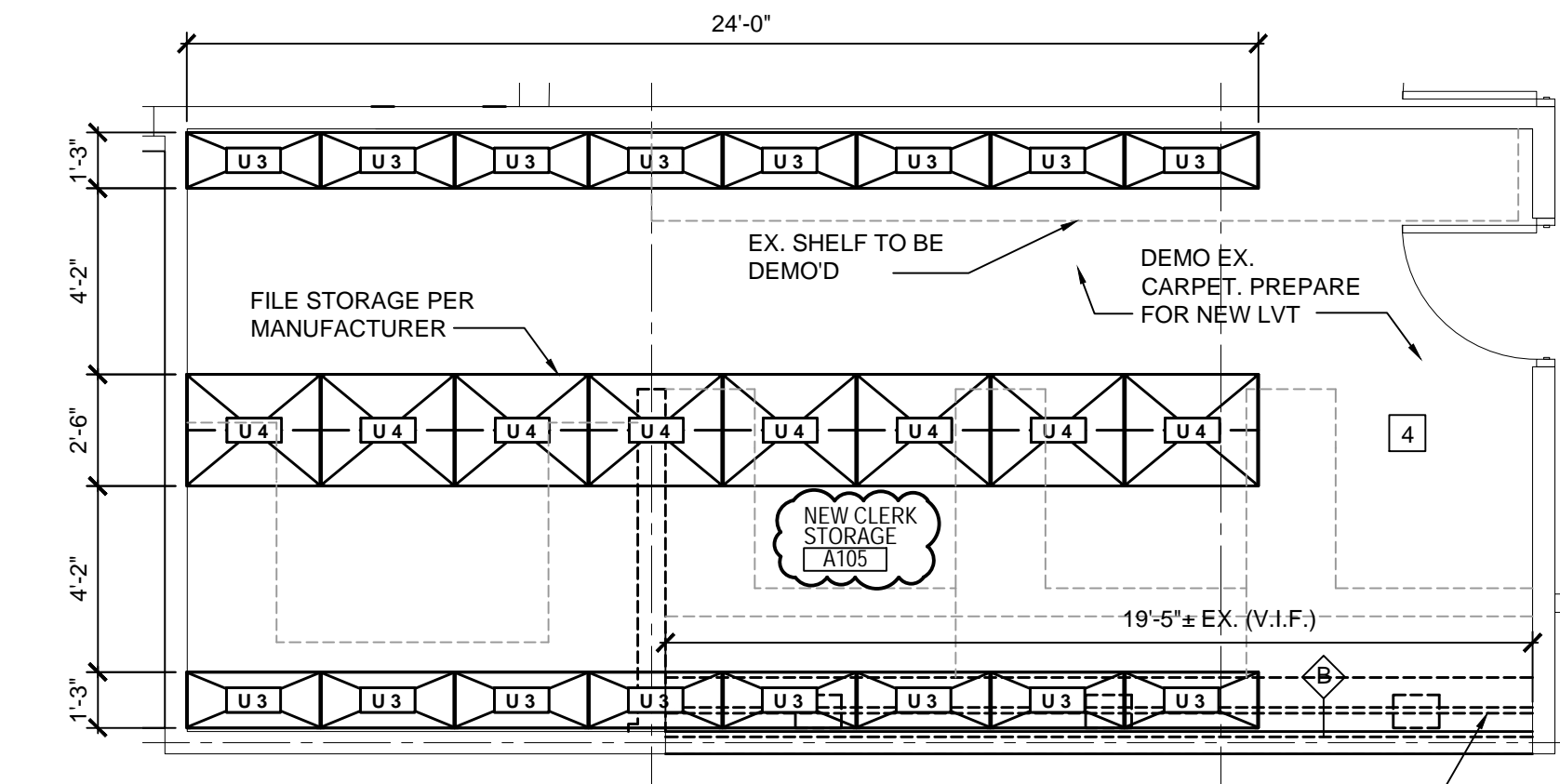

**CLEMENS CENTER
ENLARGED STATE OF MICHIGAN STORAGE PLAN**
SCALE: 1/4" = 1'-0"

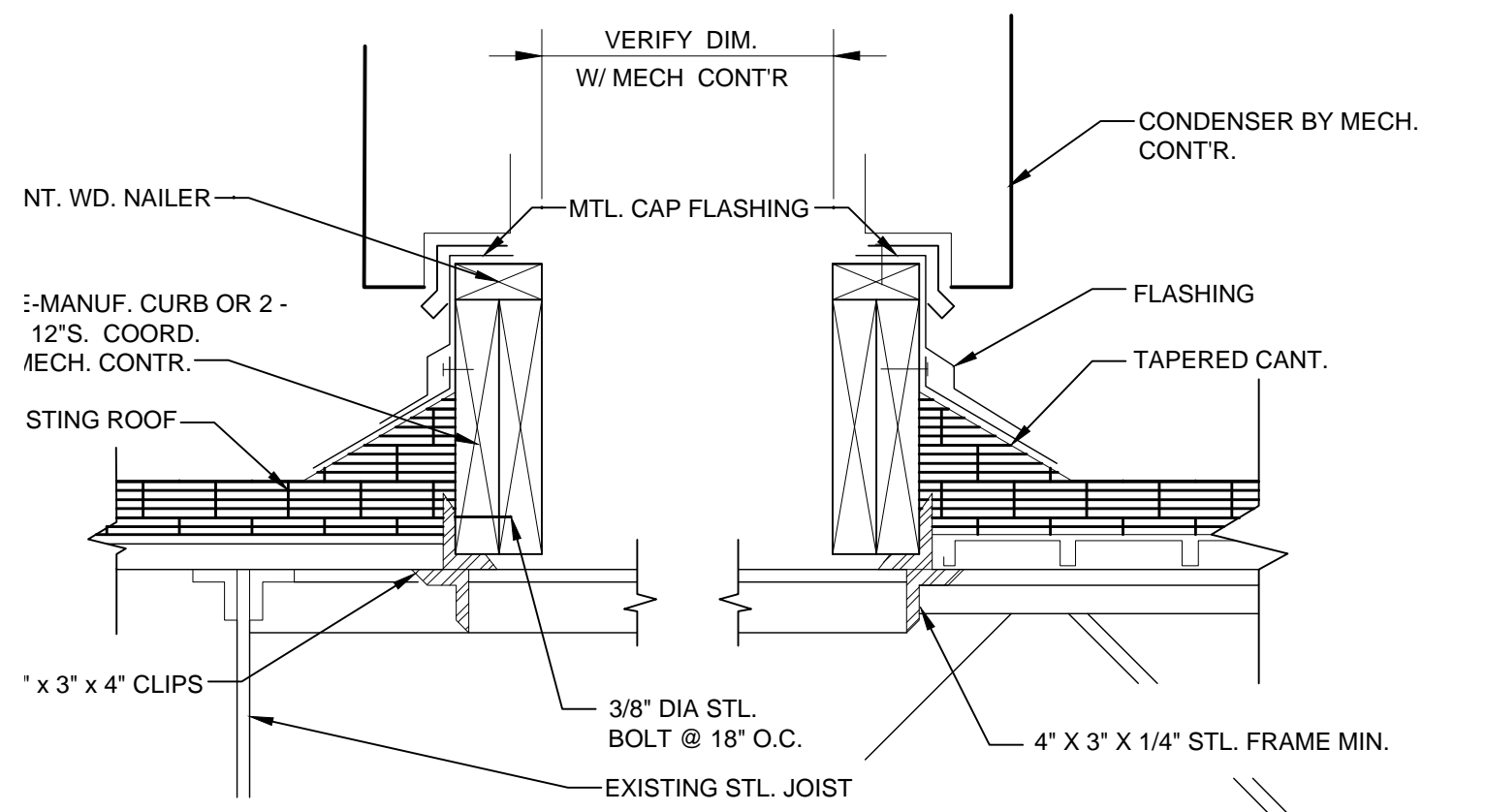

SECTION A SECTION B

6 CURB DETAIL
A1.2 N.T.S.

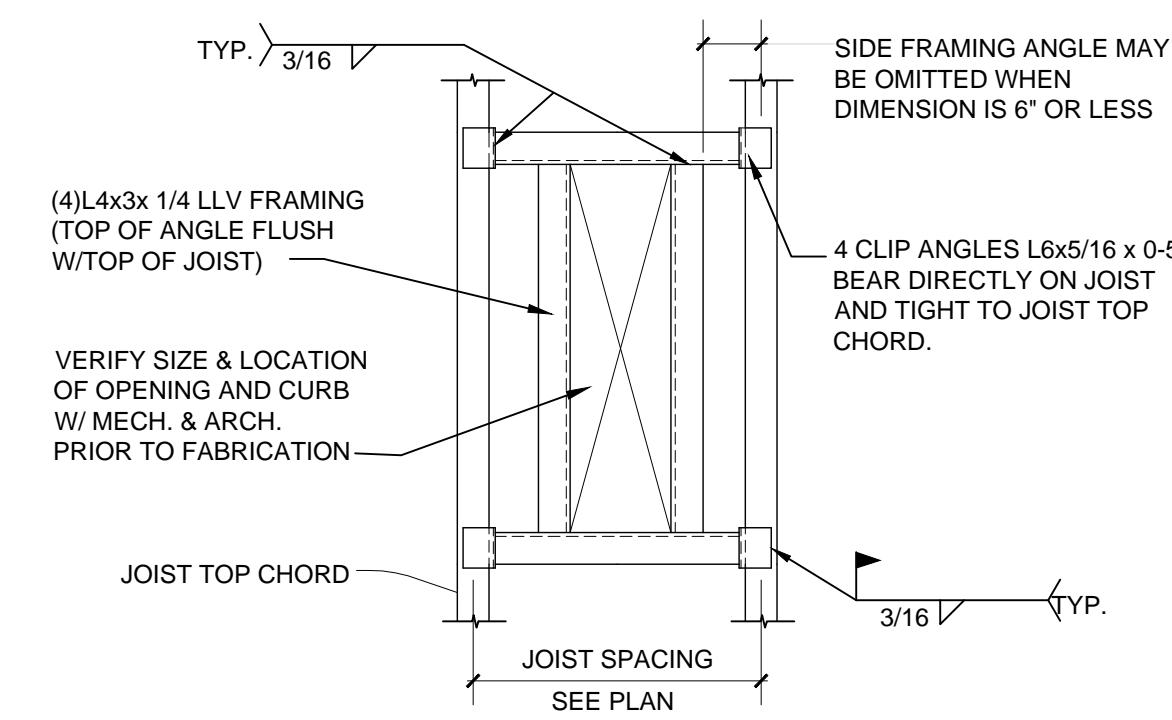

5 TYP. CURB FRAMING DETAIL
A1.2 SCALE: 1" = 1'-0"

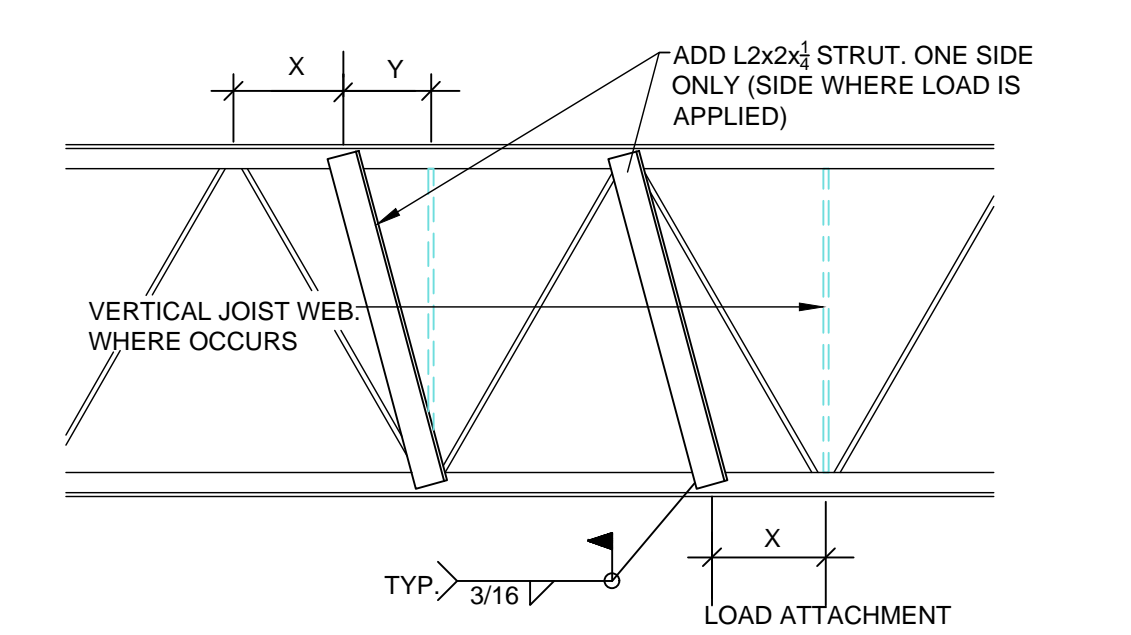

4 TYP. JOIST REINFORCEMENT DETAIL
A1.2 SCALE: 1" = 1'-0"

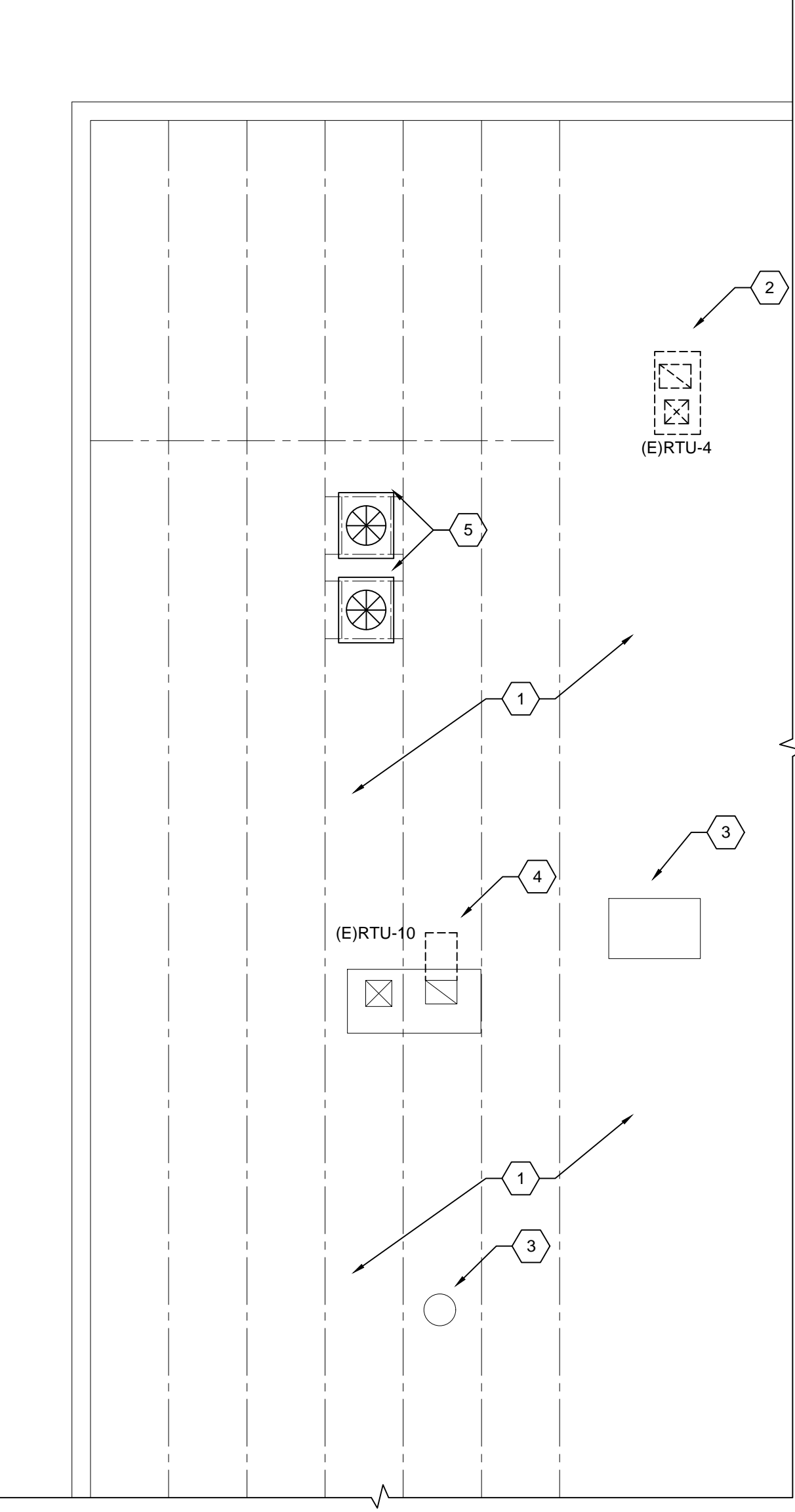

**CLEMENS CENTER
PARTIAL ROOF PLAN**
SCALE: 1/8" = 1'-0"

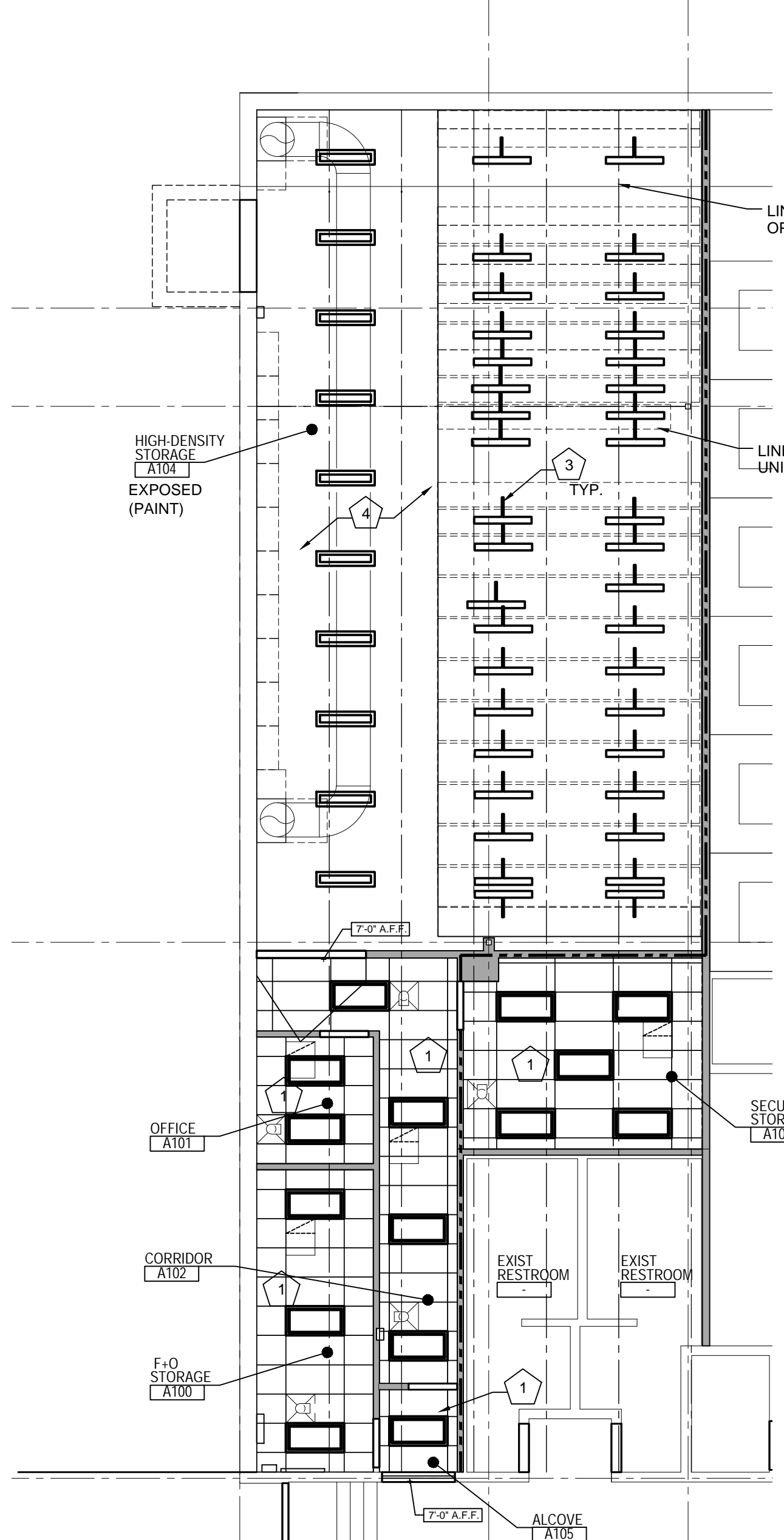

**CLEMENS CENTER
REFLECTED CEILING PLAN**
SCALE: 1/8" = 1'-0"

**NEW WORK
FLOOR PLAN KEYNOTES**

- 1 NEW WALL PARTITION - REFER TO LEGEND.
- 2 NEW DOOR, FRAME AND HARDWARE. REFER TO DOOR SCHEDULE. TOOTH-IN NEW BULLNOSE EDGE CMU (PAINT) AT BOTH JAMBS. PROVIDE NEW MASONRY LINTEL WITH 8" MIN. BEARING.
- 3 NEW QUARTZ COUNTER, BACKSPASH AND BASE CABINETS. REFER TO INTERIOR ELEVATIONS.
- 4 NEW FLOOR, WALL AND CEILING FINISHES. REFER TO ROOM FINISH SCHEDULE.
- 5 NEW GYPSUM BOARD ENCLOSURE AT EXISTING COLUMN.
- 6 HIGH-DENSITY STORAGE SYSTEM WITH SHELVING, LED LIGHTING, ETC. RAIL SYSTEM TO BE RECESSED INTO EXISTING CONCRETE FLOOR. REFER TO DEMOLITION PLAN. LEVEL FLOOR AS REQUIRED. REFER TO SPECIFICATIONS.
- 7 PROVIDE NEW PARTITION ABOVE EXISTING WALL (TIGHT TO THE DECK.)
- 8 PATCH EXISTING CONCRETE SLAB AS REQUIRED FOR NEW FLOOR DRAIN/SANITARY LINE. REFER TO MECH. DWGS. COORDINATE WITH TRADES FOR EXACT LOCATION OF EXISTING SANITARY LINE.
- 9 NEW AIR CONDITIONING UNIT. REFER TO MECH./ELECT. DWGS.
- 10 INFILL NEW TRENCH FOR NEW HIGH-DENSITY STORAGE RECESSED RAIL SYSTEM PER THE MANUFACTURER'S SPECIFICATIONS.
- 11 NEW 8'x4' MARKERBOARD. REFER TO SPECS.
- 12 NEW 4'x4' TACKBOARD. REFER TO SPECS.
- 13 NEW OPEN SHELVING UNITS. REFER TO LEGEND.

**REFLECTED CEILING
KEYNOTES**

- 1 NEW 2'x4' CEILING GRID AND TILE WITH NEW LIGHTING, DIFFUSERS, ETC. REFER TO ELECT. DRAWINGS.
- 2 NEW GYPSUM BOARD WALL HEAD (PAINT).
- 3 NEW LED AISLE LIGHT FIXTURES MOUNTED TO TOP OF SHELVING UNITS AND PROVIDED BY HIGH-DENSITY STORAGE MANUFACTURER. (TWO LIGHT FIXTURES TYPICAL AT EACH ROW WITH EXCEPTION OF THE TWO END ROWS) REFER TO ELECT. DRAWINGS.
- 4 EXPOSED STRUCTURAL DECK, JOIST AND BEAMS ABOVE (PAINT).

ROOF PLAN KEYNOTES

- 1 EXISTING BUILT-UP ROOFING SYSTEM TO REMAIN.
- 2 EXISTING ROOF TOP UNIT (RTU-4) TO BE REMOVED INCLUDING ALL DUCTWORK, ACCESSORIES, ETC. REFER TO MECH. DWGS. EXISTING CURB TO REMAIN. INFILL CURB AND CAP EXISTING OPENING. SEAL ALL PENETRATIONS WEATHER TIGHT.
- 3 EXISTING ROOF TOP UNITS, EXHAUST FANS, ETC. TO REMAIN.
- 4 EXISTING DUCTWORK TO BE REMOVED COMPLETE. CAP ALL PENETRATIONS THRU ROOF.
- 5 NEW ROOF MOUNTED CONDENSING UNITS ON EQUIPMENT RAILS. REFER TO MECH. DWGS.

IMPORTANT NOTE:
ALL EXISTING BUILT-UP ROOFING TO REMAIN. ALL WORK FLASHING, PENETRATIONS, ETC. TO BE DONE BY AN TREMCO APPROVED CONTRACTOR TO MAINTAIN WARRANTY. CONTACT EARL SRBU AT 586.933.7089 PRIOR TO CONSTRUCTION.